



Quick Change Tapping Chucks & Tap Adaptors

Model QCSL-QA-QAK



AN ISO 9001 : 2000 Certified Company



MODEL QCSL

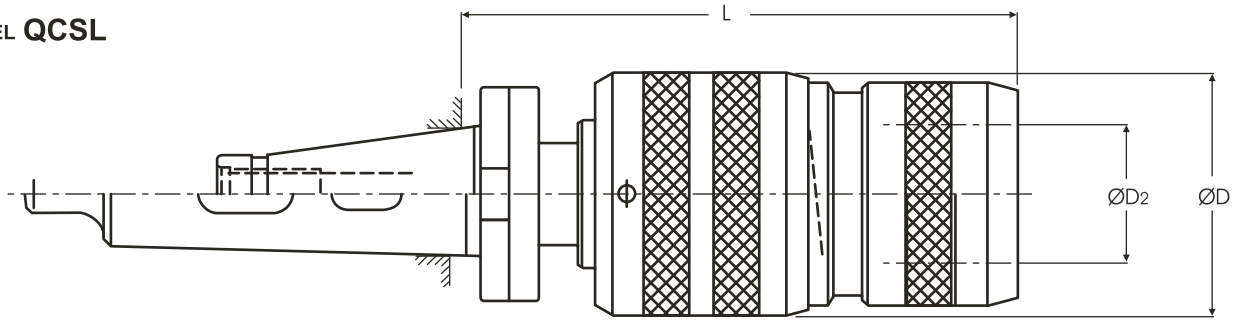

MODEL	ORDERING NO.	for taps	Torque Nm max.	Suitable Adaptors QA/QAK	Length Compensation		L	ØD	ØD ₂
					Comp.	Exp.			
QCSL 60/ISO 50	31.208.040	M 30 - M 68x6 - M 120x4	1400	Size 60	20	20	275	125	72
QCSL 60/ISO 60	31.208.060						277		
QCSL 100/ISO 60	31.209.040	M 48 - M 120x6 - M 200x3	2400	Size 100	20	20	340	156	92
QCSL 100/ISO 60	31.209.060						343		

MODEL	ORDERING NO.	for taps	Torque Nm max.	Suitable Adaptors QA/QAK	Length Compensation		L	ØD	ØD ₂
					Comp.	Exp.			
QCSL 60/MT 5	31.108.050	M 30 - M 68x6 - M 120x4	1400	Size 60	20	20	280	125	72
QCSL 60/MT 6	31.108.060						282		
QCSL 100/MT 5	31.109.050	M 48 - M 120x6 - M 200x3	2400	Size 100	20	20	345	156	92
QCSL 100/MT 6	31.109.060						347		

MODEL QA

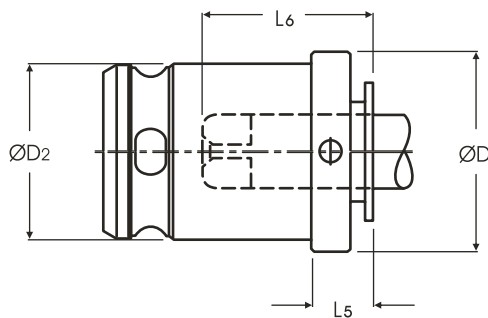

MODEL QAK

with extended range.
tap clamped
by grub screw

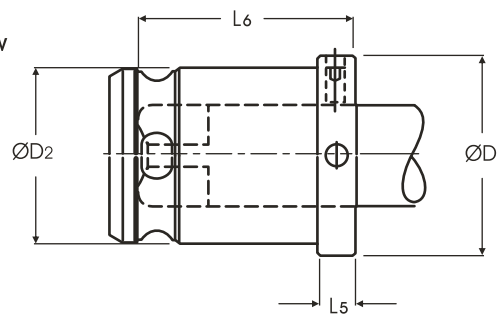

MODEL	ORDERING NO. ***	for Taps		Suitable for Chuck Size	ØD	ØD ₂	L ₅	L ₆
		Thread	Shank Ø					
QA 60	40.800...--	M 30 - M 48	22-36	60	82	72	25	78
QA 100	40.900...--	M 48 - M 120x6 - M 200x3	36-56	100	110	92	40	130

MODEL	ORDERING NO. ***	for Taps		Suitable for Chuck Size	ØD	ØD ₂	L ₅	L ₆
		Thread	Shank Ø					
QAK 60	42.800...--	>M 48 - M 68x6 - M 120x4	> 36-56	60	82	72	16	88
QAK 100	42.900...--	>M 48 - M 120x6 - M 200x3	> 56-63	100	110	92	24	115

*** : In Ordering No. mention last three digits for Shank dia. and Square size

IMI MACHINE TOOLS PVT. LTD.